

Examine all packaging material for small parts that may have come loose during shipment. Periodic checks are recommended to insure that all components are in proper position, tight and free from damage. Keep this assembly instruction for future reference. Adult assembly required. Online Parts Request: parts.request@hillsdalefurniture.com - Customer Service Phone Number: 502-562-0000

HARDWARE LIST

- B (6) Long Allen Bolts
- C (10) Spring Washers
- D (6) Flat Washers
- E (4) Camber Washers
- F (4) Wood Screws
- G (1) Allen Wrench
- H (4) Short Allen Bolts

PARTS LIST

- J (1) Seat Base Ring
- K (2) Leg Panels
- L (1) Stool Back
- M (1) Support Ring
- N (1) Seat Cushion

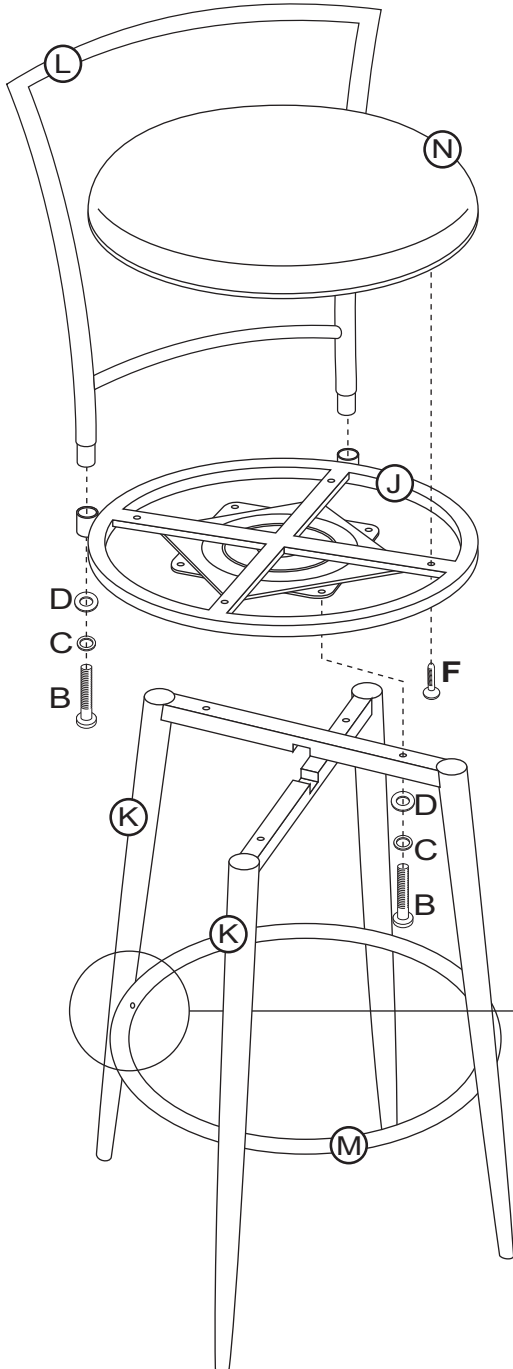
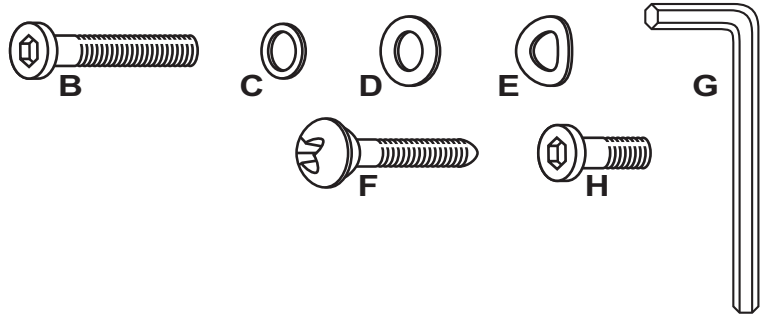

STEP 1

Begin assembly by first attaching both Leg Panels (K) together. Attach Support Ring (M) to the inside of each leg panel, using 1 Short Allen Bolt (H), 1 Spring Washer (C) & 1 Camber Washer (E) per each leg. Tighten all bolts using Allen Wrench (G) provided.

STEP 2

Next, attach Stool Back (L) to Seat Base Ring (J), by sliding each end into place and tightening using 1 Long Allen Bolt (B), 1 Spring Washer (C) & 1 Flat Washer (D) per each side. Tighten all bolts using Allen Wrench (G) provided.

STEP 3

Attach Seat Base Ring (J) to each Leg Panel (K), using 1 Long Allen Bolt (B), 1 Spring Washer (C) & 1 Flat Washer (D) per each pre-drilled hole on top of leg panels. Tighten all bolts using Allen Wrench (G) provided.

STEP 4

Finally, attach Seat Cushion (N) to Seat Base Ring (J), using 4 Wood Screws (F) to hold tight in place. Only use a phillips head screwdriver (not included) to tighten screws as power tools may result in damage to the hardware. The assembly is now complete.

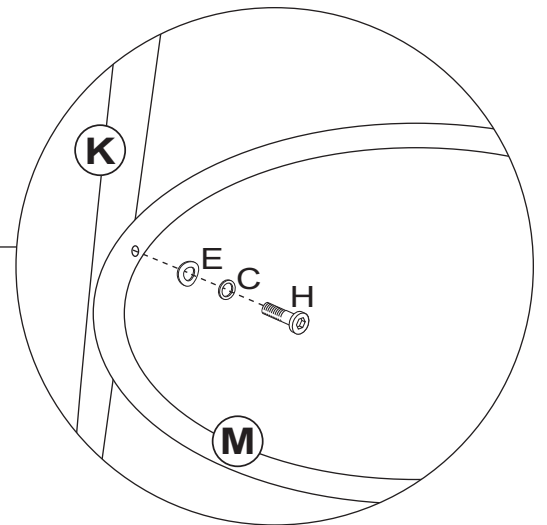

CARE & MAINTENANCE: The touch of a soft cloth is all the maintenance the finish will ever need. Please do not use harsh or abrasive cleaners for polishing, as they may cause damage to the finish. Periodic checks are recommended to make sure that all bolts, screws and nuts are securely tightened.