

DONCASTER SWIVEL STOOL KEMPTON SWIVEL STOOL

Model # 4521-826 / 4522-826 Counter Stool

Model # 4521-830 / 4522-830 Bar Stool

Date: 11-25-10

Examine all packaging material for small parts that may have come loose during shipment. Periodic checks are recommended to insure that all components are in proper position, tight and free from damage. Keep this assembly instruction for future reference. Adult assembly is required. Customer Service Phone Number: 502-562-0000

HARDWARE LIST

- A (10) Long Allen Bolts M6 x 40mm
- B (8) Short Allen Bolts M6 x 35mm
- C (18) Spring Washers 1/4"
- D (6) Small Flat Washers 13mm
- E (8) Large Flat Washers 19mm
- F (4) Wood Screws
- G (1) Allen Wrench

PARTS LIST

- K (1) Stool Back
- L (1) Seat Base
- M (1) Seat Cushion
- N (4) Leg Panels
- P (1) Small Support Ring
- Q (1) Large Support Ring

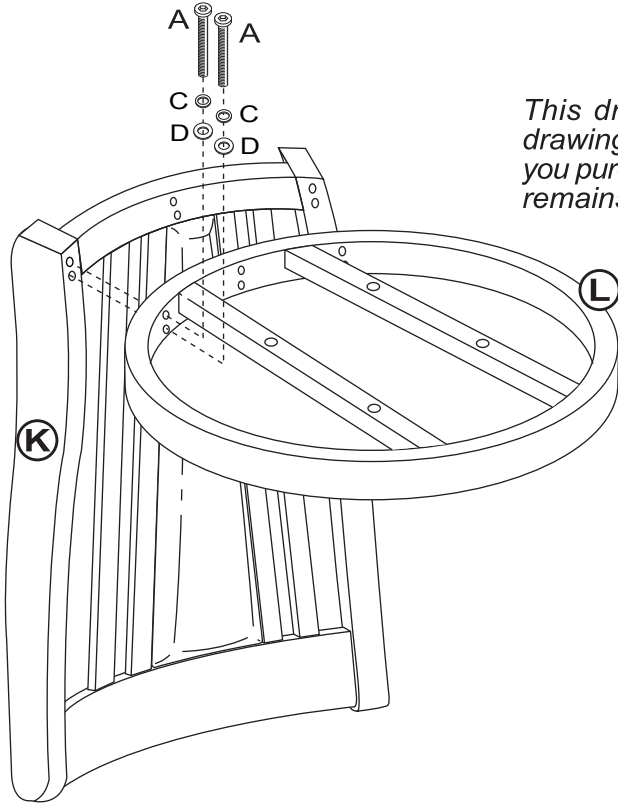
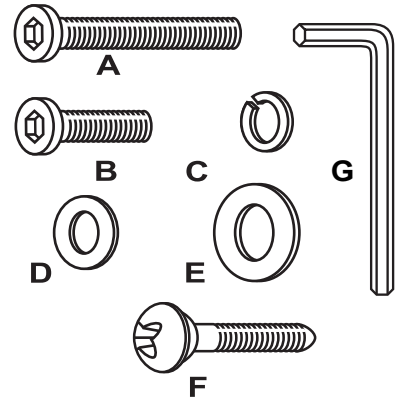

This drawing is a generic drawing of the original item you purchased. All assembly remains the same.

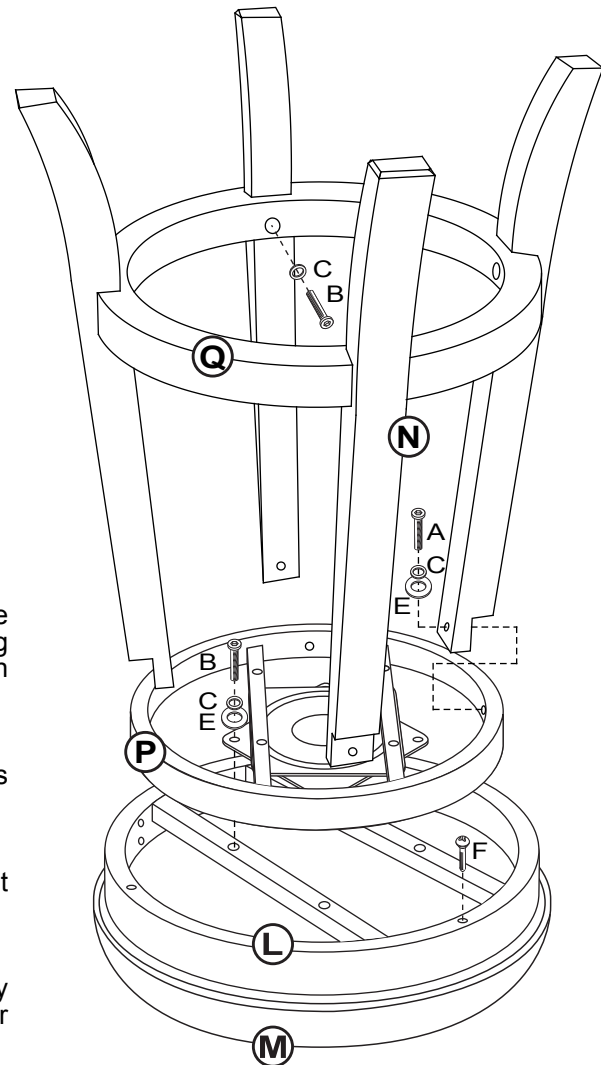

STEP 1

Begin the assembly by attaching the Seat Base (L) to the Stool Back (K). Once in place, secure each arm of the Stool Back using 2 Long Allen Bolts (A) 2 Spring Washer (C) & 2 Small Flat Washer (D) per each side. Tighten all bolts using Allen Wrenches (G).

STEP 2

Next attach the Seat Cushion (M) to the Seat Base (L) by using 4 Wood Screws (F). Tighten screws using a philips head screwdriver (not included).

STEP 3

Attach each Leg (N) to the Large Support Ring (Q) by using 1 Short Allen Bolt (B) & 1 Spring Washer (C) per each Leg. Do not fully tighten bolts.

STEP 4

Slowly insert the assembled Leg base into Small Support Ring (P) in place by using 1 Long Allen Bolt (A), 1 Spring Washer (C) & 1 Large Flat Washer (E) per each Leg. Tighten all bolts using Allen Wrench (G).

STEP 5

Finally, attach the Seat Base (L) to the pre-assembled Swivel Metal Plate using 1 short Allen Bolts (B), 1 Spring Washer (C) & 1 Large Flat Washer (E) to secure in place from the bottom. Tighten all bolts. The assembly is now complete.

CARE & MAINTENANCE: The touch of a soft cloth is all the maintenance the finish will ever need. Please do not use harsh or abrasive cleaners for polishing, as they may cause damage to the finish. Periodic checks are recommended to make sure that all bolts, screws and nuts are securely tightened.