

Examine all packaging material for small parts that may have come loose during shipment. Periodic checks are recommended to insure that all components are in proper position, tight and free from damage. Keep this assembly instruction for future reference. Adult assembly is required. Customer Service Phone Number: 502-562-0000

HARDWARE LIST

- A (8) Allen Bolts 1/4" x 3/4"
- B (4) Allen Bolts 1/4" x 1/2"
- C (12) Spring Washers 1/4"
- D (12) Flat Washers 1/4"
- E (4) Wood Screws
- F (1) Allen Wrench

PARTS LIST

- G (1) Stool Back
- H (1) Seat Base
- J (2) Front Legs
- K (1) Support Brace
- L (1) Seat Cushion

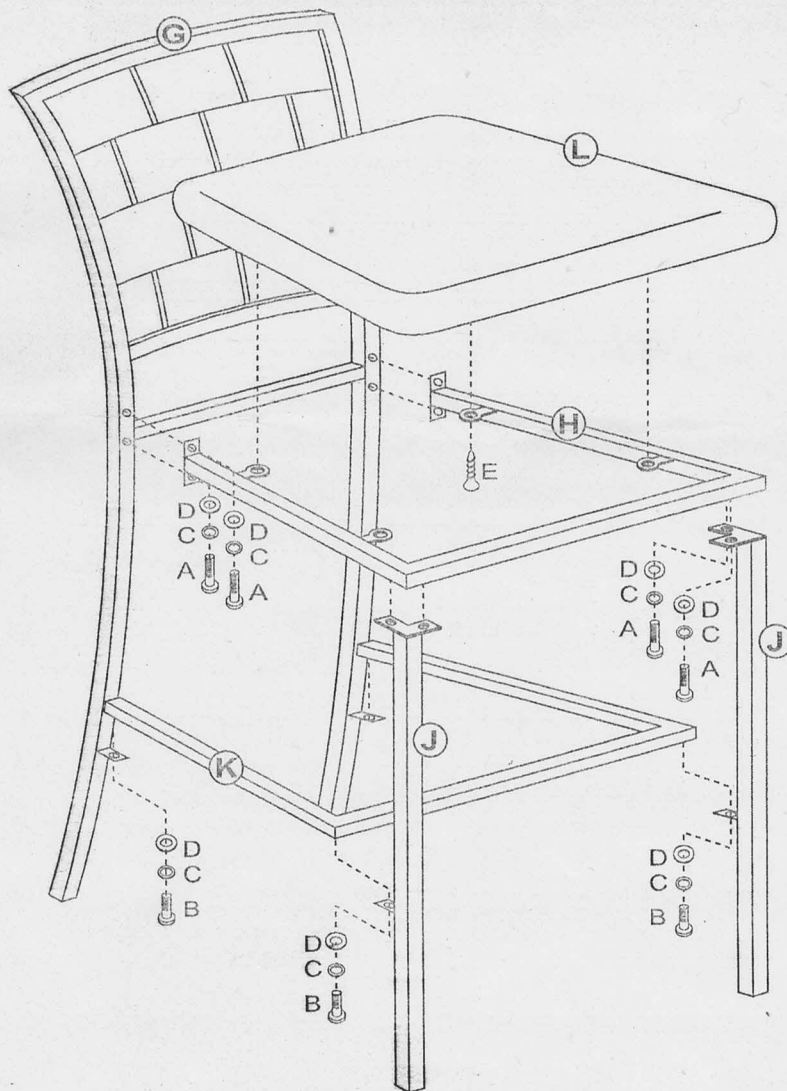
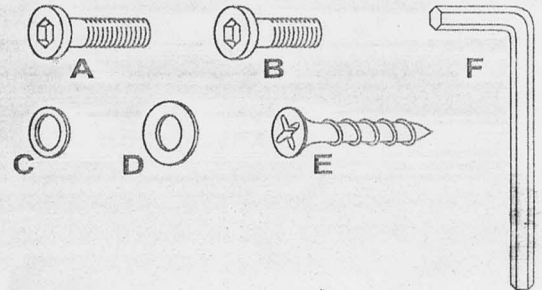

STEP 1

Begin assembly by attaching the Seat Base (H) to the Stool Back (G) using 2 Allen Bolts (A), 2 Spring Washers (C), & 2 Flat Washers (D) per each side. Tighten all bolts using the Allen Wrench (F) that has been provided.

STEP 2

Next, attach each Front Leg (J) to the bottom of the Seat Base (H) using 2 Allen Bolts (A), 2 Spring Washers (C), & 2 Flat Washers (D) to secure in place. Do not fully tighten bolts for this step.

STEP 3

Attach the Support Brace (K) to each Front Leg (J) and each leg on the Stool back (G) using 1 Allen Bolt (B), 1 Spring Washer (C), & 1 Flat Washer (D) per each leg. Tighten all bolts from Steps 2 and 3.

STEP 4

Finally, attach the Seat Cushion (L) to the top of the Seat Base (H) using 4 Wood Screws (E) to secure in place. Tighten all screws only using a philips head screwdriver (not included). The assembly is now complete.