

# Oak View Stools

Examine all packaging material for small parts that may have come loose during shipment. Periodic checks are recommended to insure that all components are in proper position, tight and free from damage. Keep this assembly instruction for future reference. Adult assembly required. Online Parts Request Form: [www.hillsdalehouse.com/parts\\_request.html](http://www.hillsdalehouse.com/parts_request.html)

## HARDWARE LISTS

- A (4) Allen Bolts
- B (4) Spring Washers
- C (4) Metal Washers
- D (1) Allen Wrench

## PARTS LISTS

- E (1) Stool Top
- F (1) Stool Base

Tools Required: Allen Wrench (Supplied)

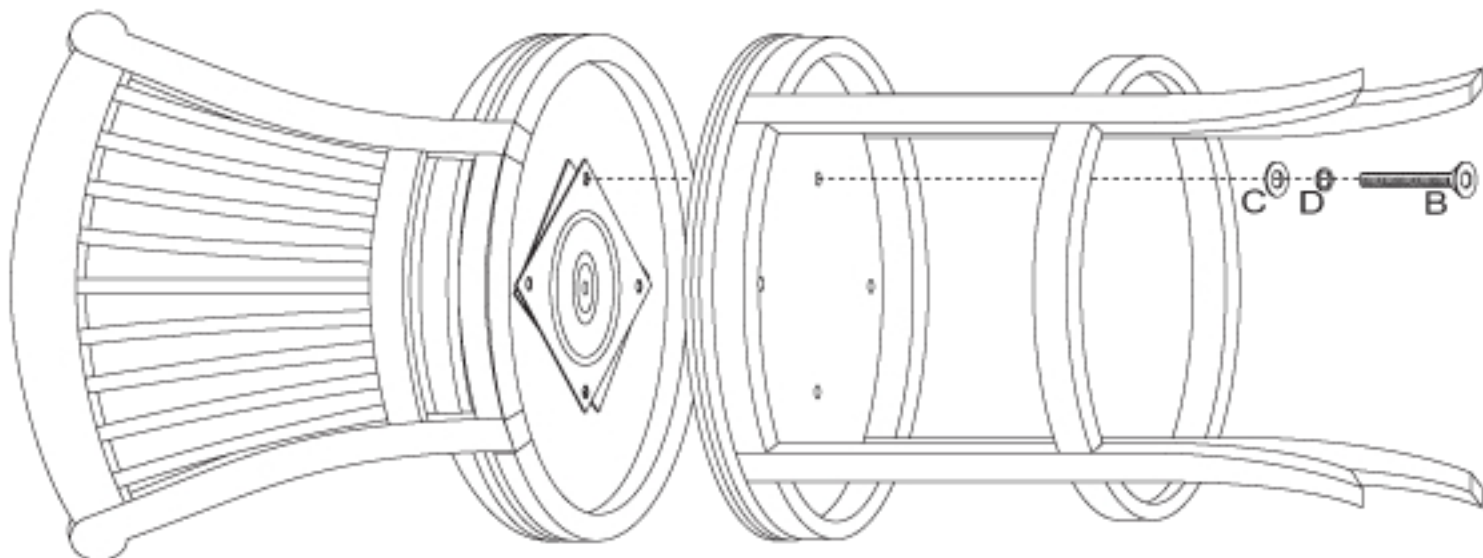
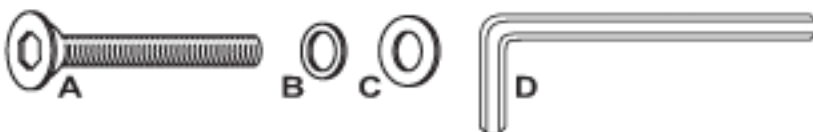

*Image represents a generic drawing of the original item that you have purchased.*

## STEP 1

Begin assembly by attaching both Arms (J) to Seat Back (G) using 2 Long Allen Bolts (A), 2 Spring Washers (D) and 2 Metal Washers (C) at the bottom per each arm. Next, use 1 Long Allen Bolt (A), 1 Spring Washer (D) and 1 Metal Washer (C) at the top on the back side, per each arm. Tighten All Bolts.

## STEP 2

Attach Seat Base (H) to Seat Back (G) using 4 Short Allen Bolts (B), 4 Spring Washers (D) and 4 Metal Washers (C) to hold in place. Tighten All Bolts. See Figure above for details. Assembly is now complete.

**CARE & MAINTENANCE:** The touch of a soft cloth is all the maintenance the finish will ever need. Please do not use harsh or abrasive cleaners for polishing, as they may cause damage to the finish. Periodic checks are recommended to make sure that all bolts, screws and nuts are securely tightened.